

Stepper Motor M311

SPECIFICATIONS

PHASE	STEP ANGLE	CONNECTION STYLE	CURRENT	RESISTANCE	INDUCTANCE	HOLDING TORQUE	CLASS OF INSULATION	WEIGHT
	DEG/STEP		A	ohms±10%	mH±20%	$\square z_{in}(N.m)$		Kg
2	1.8	parallel	5.0	0.4	1.8	311(2.2)	B	1.1
2		series	2.5	1.6	7.2	311(2.2)		
4		unipolar	3.5	0.8	1.8	212(1.5)		

DIMENSION:

Units :mm

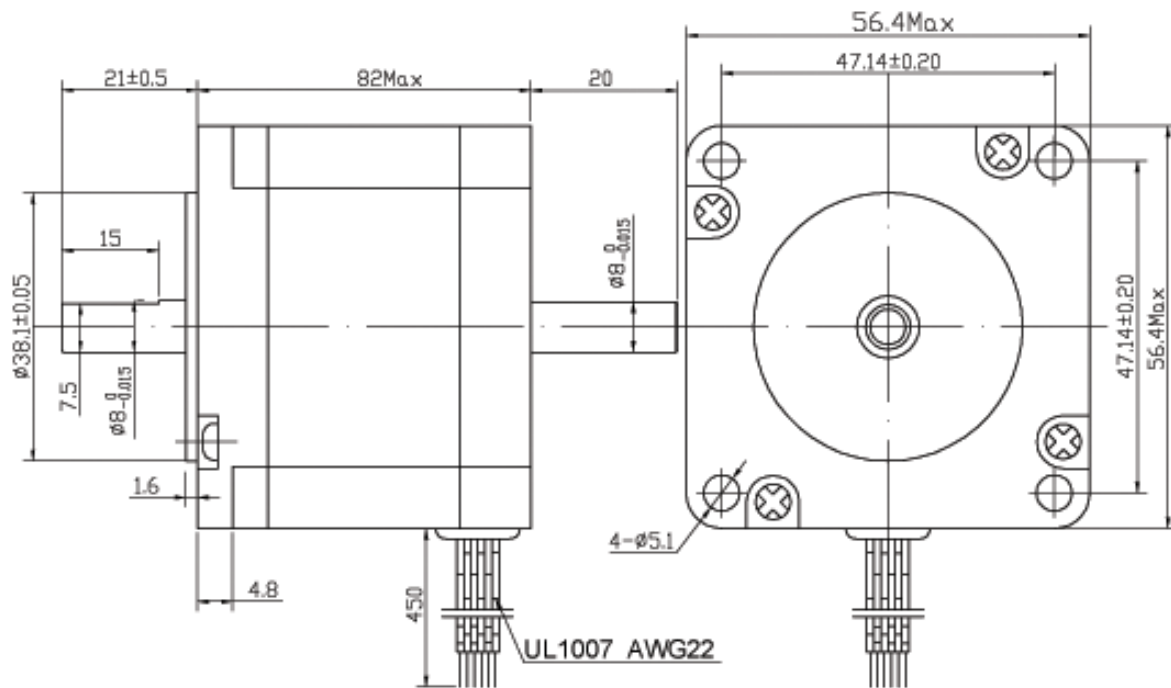

WIRING DIAGRAM

Bipolar Series

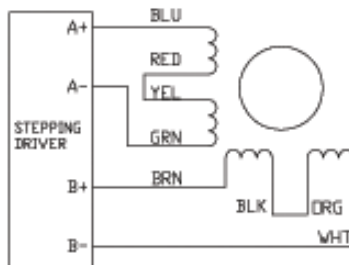

Bipolar Parallel

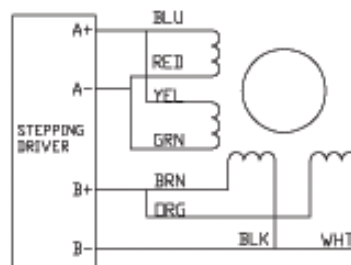

Unipolar

