

Motiontek Drives System

Rack Helical Teeth material C45 Steel (C)

Pressure angle 20°

Predrilled Holes (N)= ∅ 5.4mm

All measurement are in metric mm, each inch = 25.4 mm

Machined at each end for end to end continuous mounting

Code R - H - H - C - 10 - 0500						
Digit	1	2	3	4	5 ~ 6	7 ~ 10
Description	R = Rack	S = Straight Teeth H = Helical Teeth	H = Holes N = No Holes	C= C45 Material	10= Module 1.0 15= Module 1.5 20= Module 2.0	Length

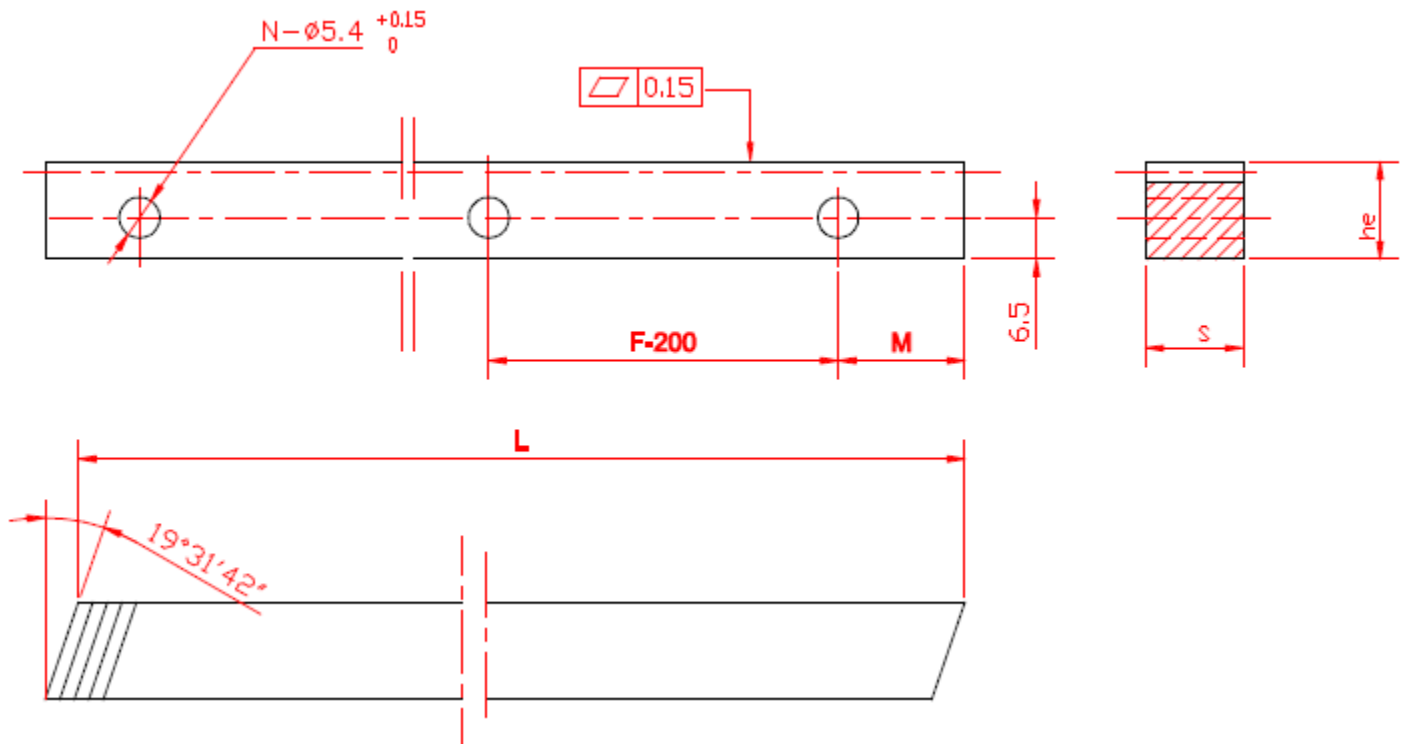

Part No.	Module	Length	he	hp	S	L Actual	F-200	No of holes	M	Weight
RHHC100500	1.0	500	15	14	15	500	2	3	50	
RHHC101000	1.0	1000	15	14	15	1000	4	5	100	
RHHC101500	1.0	1500	15	14	15	1500	7	8	50	
RHHC102000	1.0	2000	15	14	15	2000	9	10	100	
RHHC150500	1.5	500	15	13.5	15	500	2	3	50	
RHHC151000	1.5	1000	15	13.5	15	1000	4	5	100	
RHHC151500	1.5	1500	15	13.5	15	1500	7	8	50	
RHHC152000	1.5	2000	15	13.5	15	2000	9	10	100	